

2. Technik / Grundlagen	2
2.5.4 Türstärke 54 mm	2

Türstärke 54 mm

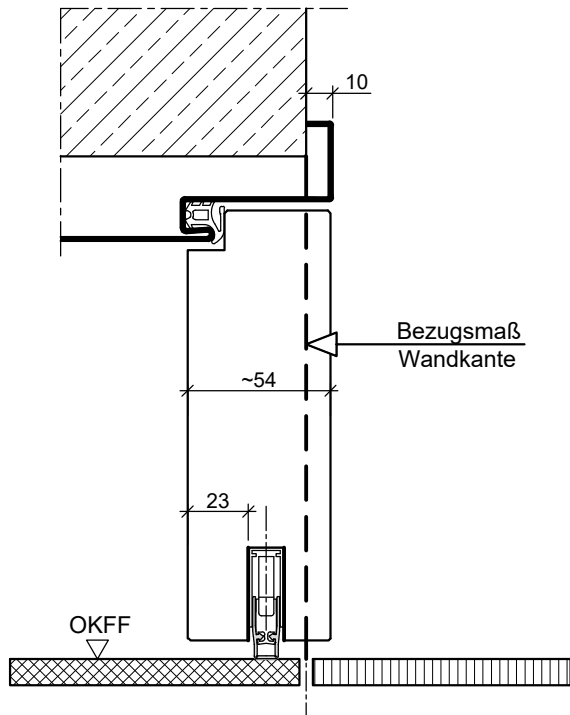

HW54-stumpf mit Leibungsfalz in Stahlzarge

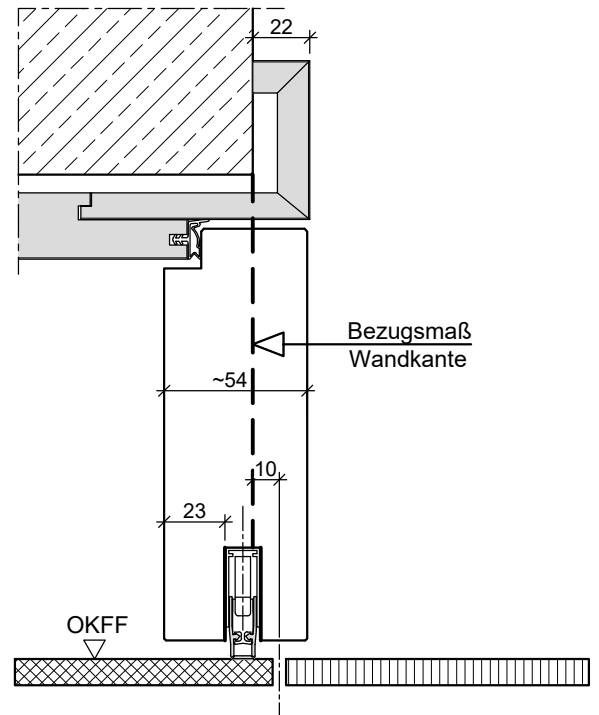

HW54-stumpf mit Leibungsfalz in Holzumfassungszarge

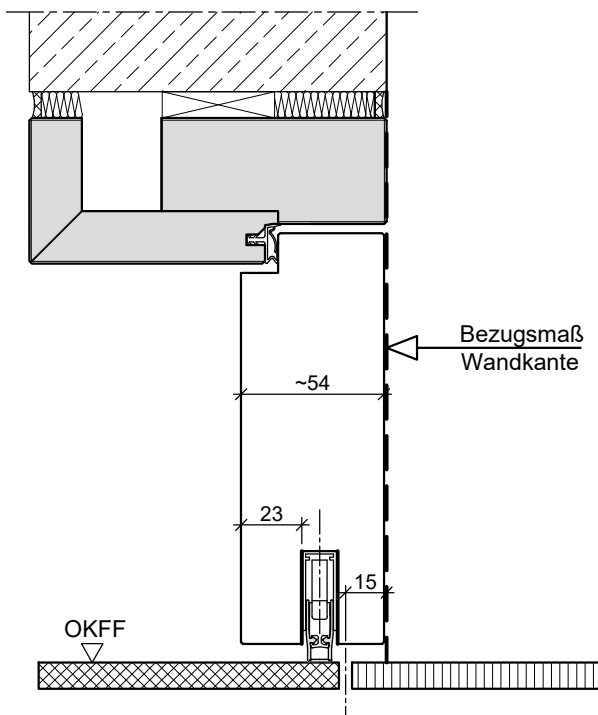

HW54-stumpf mit Leibungsfalz in Holzblockzarge

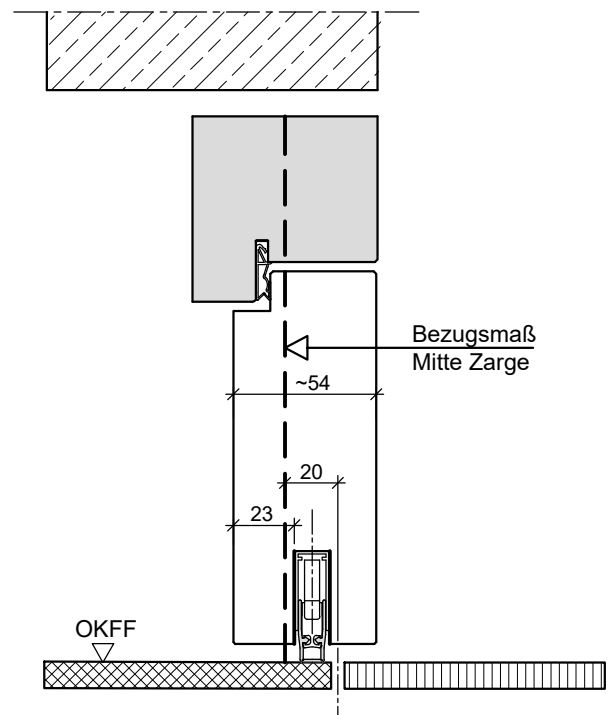

HW54-stumpf mit Leibungsfalz in Stockzarge

Türstärke 54 mm

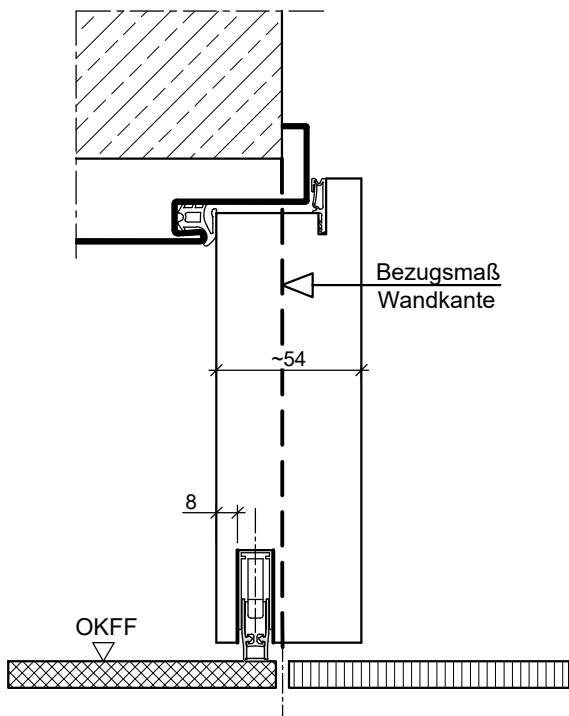

HW54-gefälzt Stahlzarge

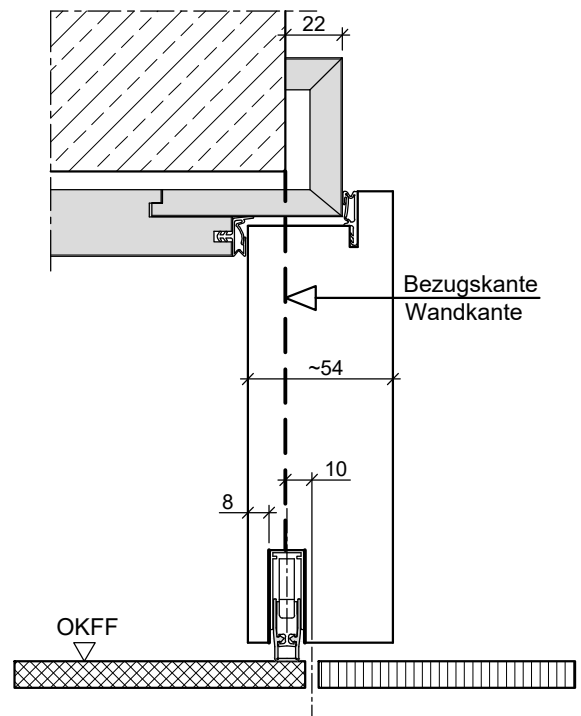

HW54-gefälzt in Holzumfassungszarge

Türstärke 54 mm

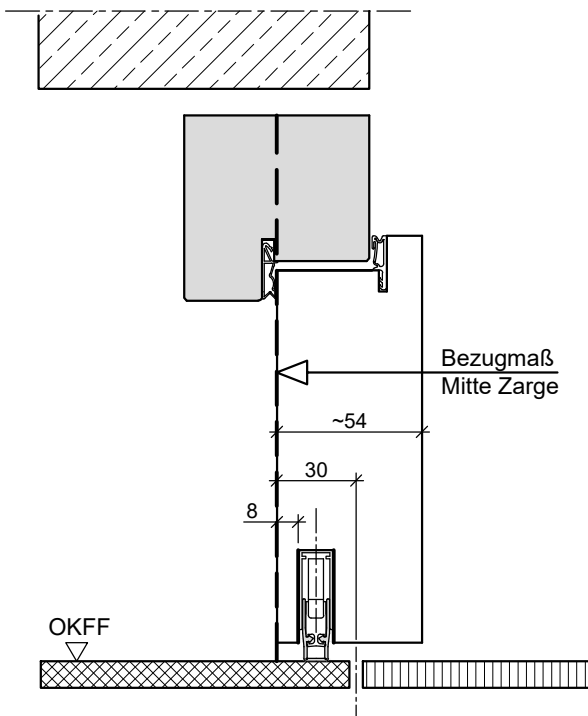

HW54-gefälzt in Stockzarge

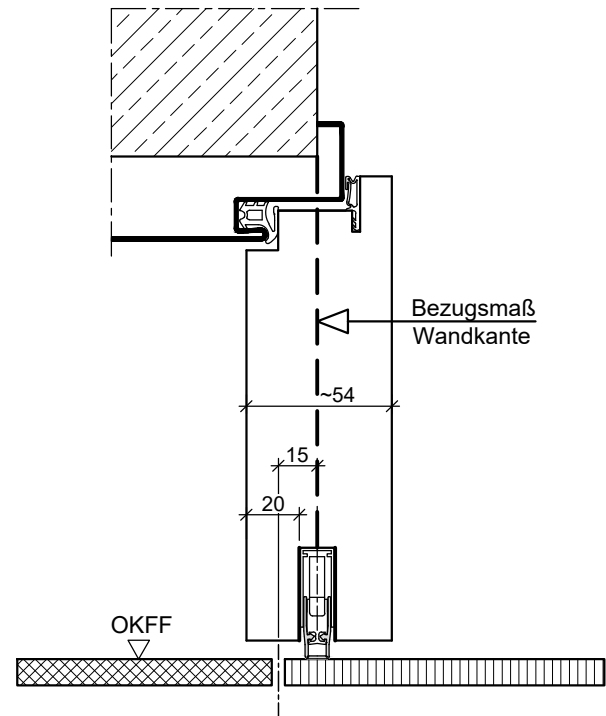

HW54-auflegend mit Doppelfalz in Stahlzarge

Türstärke 54 mm

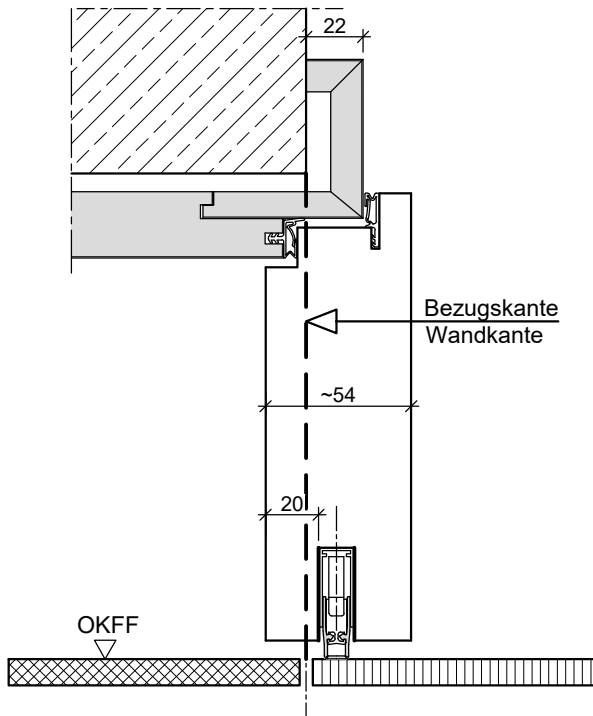

HW54-aufliiegend mit Doppelfalz
in Holzumfassungszarge

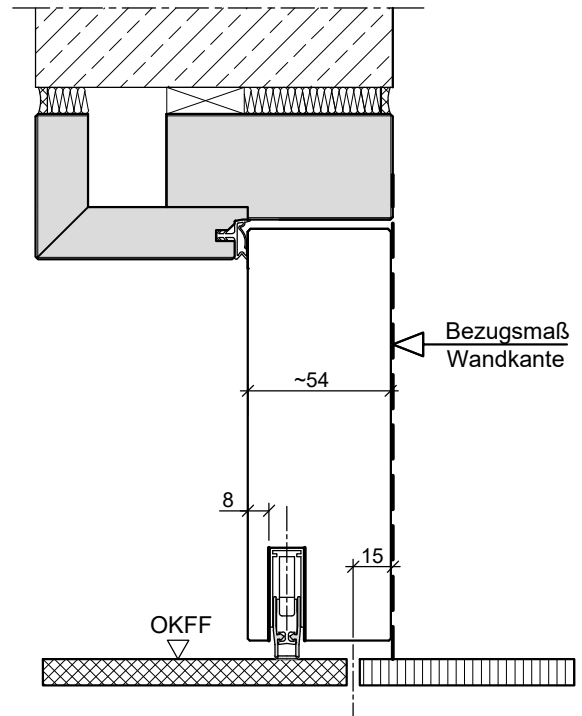

HW54-stumpf
in Holzblockzarge

Türstärke 54 mm

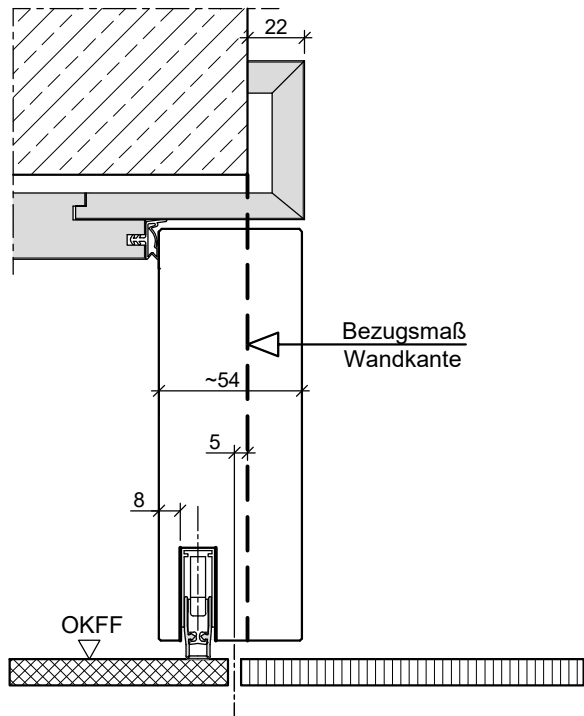

HW54-stumpf
in Holzumfassungszarge

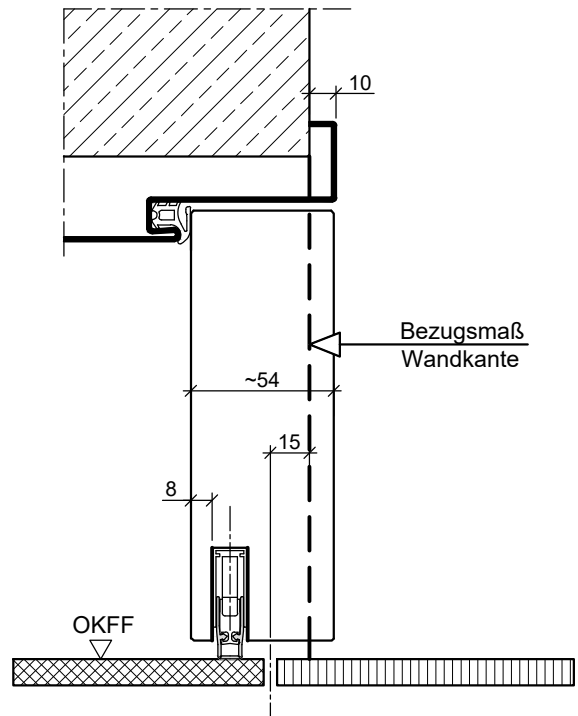

HW54-stumpf in Stahlzarge