

<b>2. Technik / Grundlagen</b> .....	2
2.5.1 Türstärke 40 mm .....	2

Türstärke 40 mm

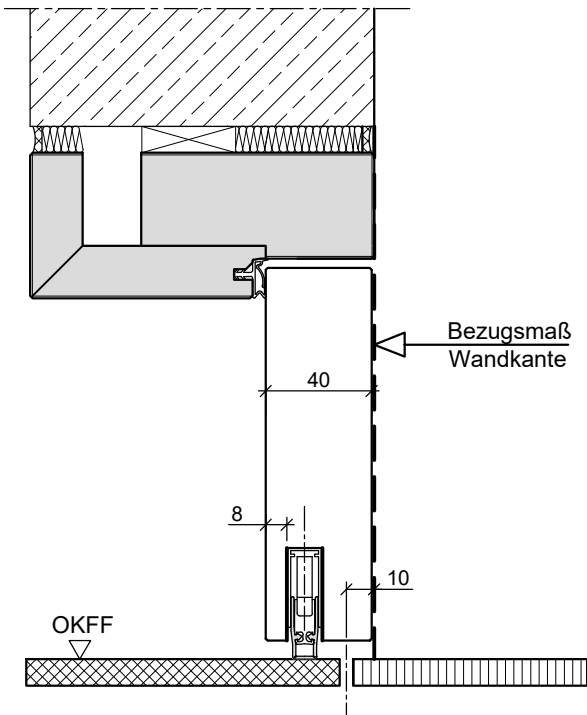

HW40-stumpf in Holzblockzarge

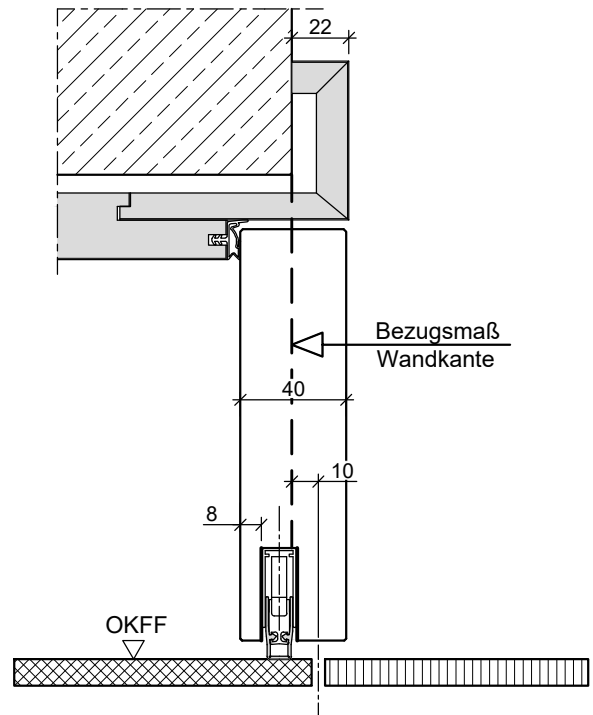

HW40-stumpf in Holzumfassungszarge

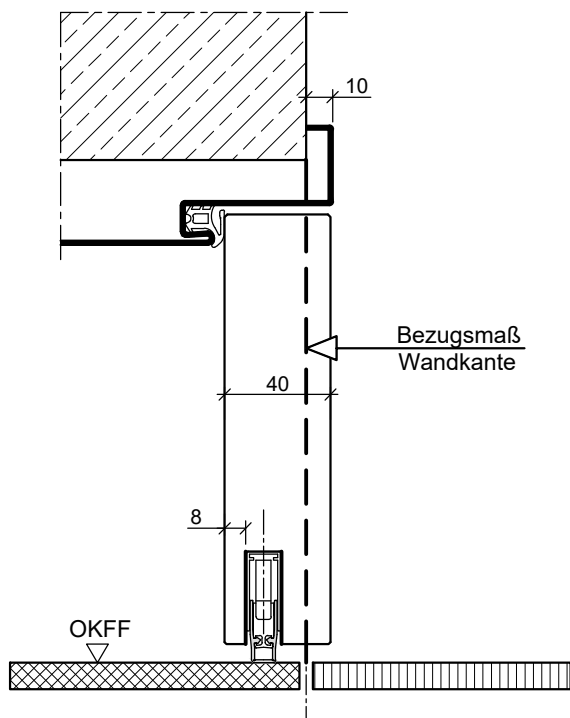

HW40-stumpf in Stahlzarge

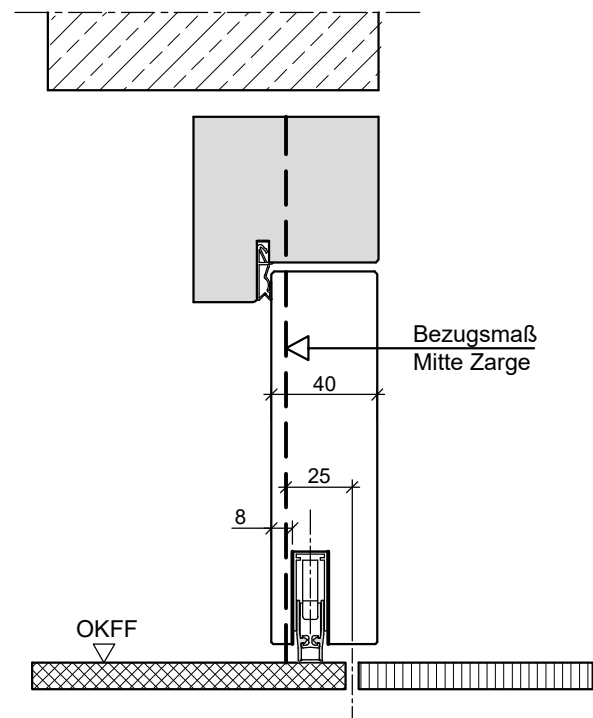

HW40-stumpf in Stockzarge

Türstärke 40 mm

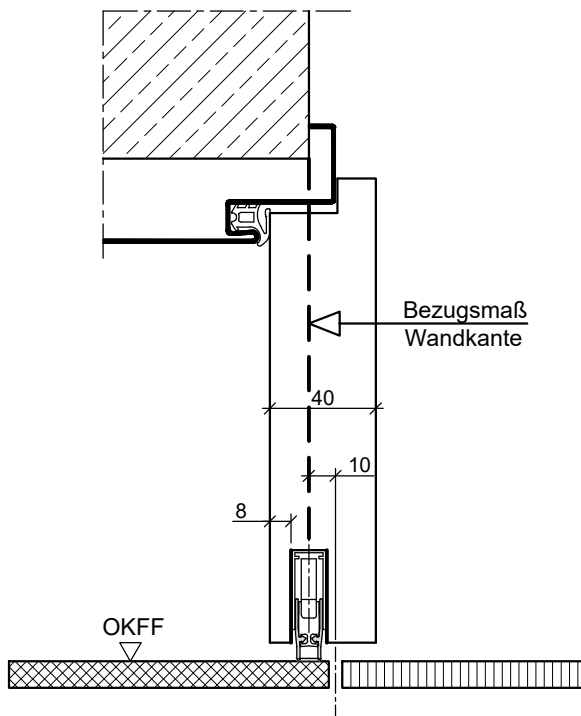

HW40-gefälzt Stahlzarge

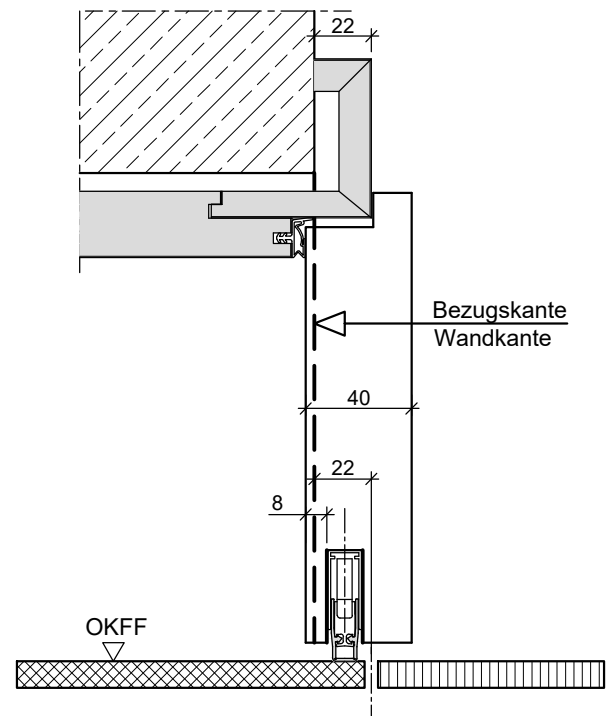

HW40-gefälzt in Holzumfassungszarge

Türstärke 40 mm

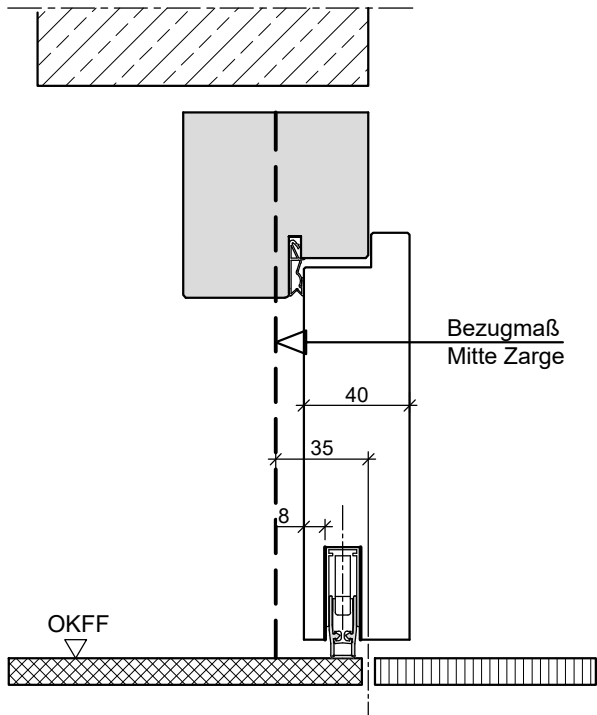

HW40-gefälzt in Stockzarge